

836 MHz/1.95GHz Dual-Band Class-E Power Amplifier Using Composite Right/Left-Handed Transmission Lines

Seung Hun Ji, Gyu Seok Hwang , Choon Sik Cho, Jae W. Lee and Jacheung Kim*

School of Electronics, Telecommunication and Computer Engineering, Hankuk Aviation University, 200-1, Hwajeon-dong, Goyang, Gyeonggi-do, Korea, 412-791, Telephone : +82-2-300-0140 Fax:+82-2-3159-9969

Email: neonjsh@hau.ac.kr, cscho@hau.ac.kr, kakaron21@nate.com

*School of IT Engineering, Information and Communication University, 119, Munji-ro, Yusong Daejeon, Korea, 035-714, Telephone:+82-42-866-6238 Fax:+82-42-866-6838

Abstract — A dual-band Class-E power amplifier using composite right/left-handed transmission lines is proposed. Dual-mode operation is achieved by the frequency offset and nonlinear phase slope of CRLH TL for the matching network of power amplifiers. The frequency ratio of two operating frequencies is not necessarily an integer. Two operating frequencies are chosen 836MHz and 1.95GHz in this work. The simulated results show that output power of 24.9 and 24.1 dBm was obtained at 836MHz and 1.95GHz, respectively. In terms of maximum PAE, we obtain 48.63% and 48.29% at two operating frequencies.

Index Terms — Class-E, power amplifier, dual-band, CRLH-TL.

I. INTRODUCTION

Recently, radio frequency (RF) equipment is required to operate seamlessly using different wireless communications standards and spectra that are in use around the world. Various efforts have been made to realize multi-band operation. Adaptable RF circuits whose performance can be changed without loss of performance according to the wireless environment will be necessary to achieve this concept [1]. Power amplifiers are a key component in mobile terminals and dual-band components are beneficial to reduce the number of circuit components in modern wireless communication systems having two frequency bands. In this paper, the simple features of metamaterial [2] based on transmission lines are used to implement a matching network for class-E power amplifier for dual-mode operation. As shown in [3], composite right/left-handed transmission lines (CRLH-TL) possess interesting phase characteristics such as, anti-parallel phase and group velocity and non-linear phase slope. Thus far this novel transmission media has been used in the implementation of passive devices such as couplers, resonators, and antennas.

The use of CRLH-TL allows for the manipulation of phase slope and phase offset at zero frequency. This attribute can be used to specify the phase delay of a CRLH-TL at different harmonic frequencies to create the necessary impedance for proper matching network. Using this method a CRLH-TL network can be used to match circuit components of dual-mode class-E power amplifier [4].

II. DUAL-BAND CLASS-E POWER AMPLIFIER DESIGN

The circuit topology for the class-E power amplifier [5] is shown in Fig. 1. It consists of a transistor acting as a switch, a shunt capacitor C_s across the switch and the matching network using microstrip lines.

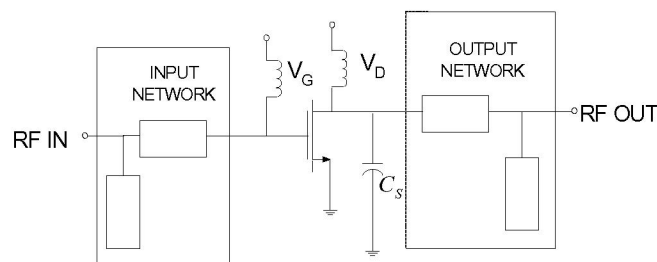

Fig. 1. The class-E power amplifier circuit topology.

The CRLH-TL, which is the combination of a left-handed (LH) TL and a right-handed (RH) TL, is proposed in [4]. The equivalent lumped elements model of the LH-TL exhibits positive phase response (phase lead). On the other hand, the RH-TL has negative phase response (phase lag). Therefore, CRLH-TL can substitute for the matching network using microstrip lines in Fig. 1. For example, Fig. 2. shows the lumped elements model for CRLH-TL when we use one of unit cell ($N = 1$) [4].

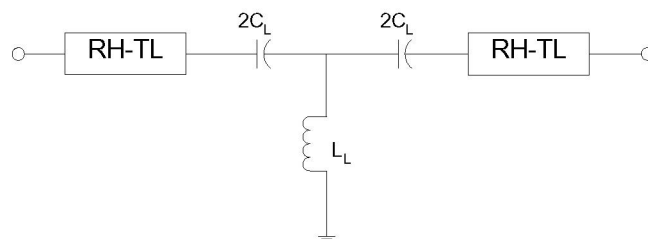

Fig. 2. The lumped elements model for the CRLH-TL when $N=1$. When the series and shunt resonances are equal : $L_R C_L = L_L C_R$, the structure is said to be balanced [3]. In the balanced condition, we can approximated the phase response :

$$\phi_C = \phi_R + \phi_L \quad (1)$$

$$\phi_R \approx -N2\pi f \sqrt{L_R C_R} \quad (2)$$

$$\phi_L \approx \frac{N}{2\pi f} \sqrt{L_L C_L} \quad (3)$$

And Z_{0R} and Z_{0L} are the characteristic impedance defined as

$$Z_{0R} = \sqrt{\frac{L_R}{C_R}} = Z_{0L} = \sqrt{\frac{L_L}{C_L}} = Z_0^{CRLH} \quad (4)$$

And unlike the ideal case, the CRLH-TL has innate LH and RH cutoff frequencies as [6]

$$f_c^{LH} = \frac{1}{4\pi \sqrt{L_L C_L}} \quad (5)$$

$$f_c^{RH} = \frac{1}{\pi \sqrt{L_R C_R}} \quad (6)$$

If the operating frequencies are chosen to be f_1 and f_2 , the phase response will be $-\phi_A$ at f_1 and $-\phi_B$ at f_2 in unit matching TL[4]. In Fig. 3, the phase response of CRLH-TL at two frequencies can be written as

$$\phi_C(f_1) = -\phi_A \quad (7)$$

$$\phi_C(f_2) = -(\pi + \phi_B) \quad (8)$$

From (1)-(3), (7) and (8) can be written as

$$P = 2\pi N \sqrt{L_R C_R} \quad (9)$$

$$Q = \frac{N}{2\pi \sqrt{L_L C_L}} \quad (10)$$

$$-Pf_1 + \frac{Q}{f_1} \approx -\phi_A \quad (11)$$

$$-Pf_2 + \frac{Q}{f_2} \approx -(\pi + \phi_B) \quad (12)$$

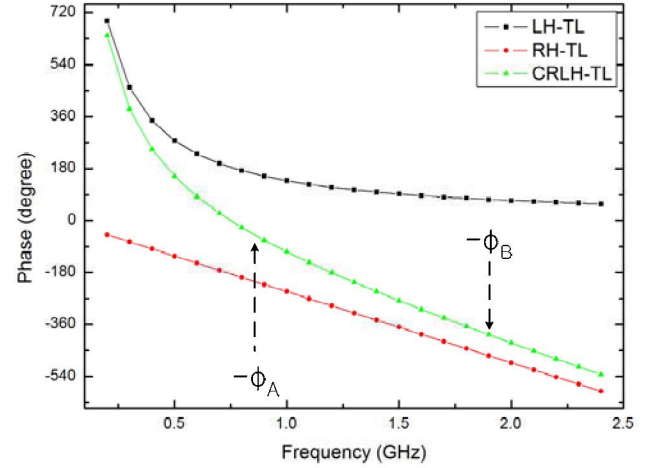

Fig. 3. The phase response of CRLH-TL.

For given f_1 and f_2 , solving for P and Q in (11) and (12) to obtain [4]:

$$P \approx \frac{(\pi + \phi_B)f_2 - \phi_A f_1}{f_2^2 - f_1^2} \quad (13)$$

$$Q \approx \frac{(\pi + \phi_B) - \phi_A}{\frac{1}{f_1^2} - \frac{1}{f_2^2}} \quad (14)$$

f_c^{LH} is calculated from (5). If $f_c^{LH} < f_1$, the design is complete. Otherwise, the design is performed again with a larger N [4]. P , Q , Z_{0R} and Z_{0L} are used to determine a C_L , L_L and physical length of RH TL (where Z_{0R} , Z_{0L} and Z_0^{CRLH} are fixed as 50Ω). Finally, CRLH-TLs were placed in matching network instead of microstrip lines to implement a dual-band operation. Fig. 4 shows the proposed dual-band class-E power amplifier using CRLH-TLs.

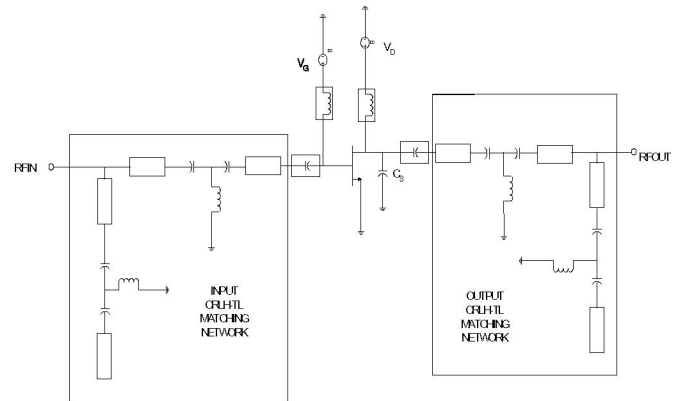

Fig. 4. The proposed dual-band class-E power amplifier using CRLH-TLs.

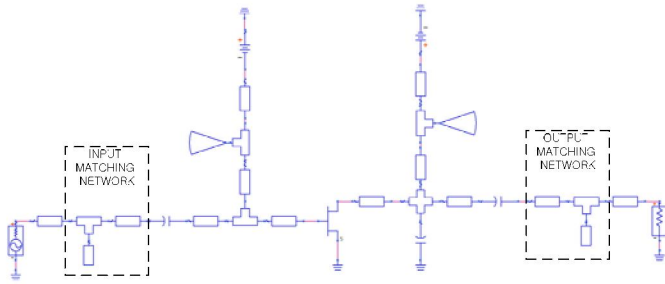

Fig. 5. The simulation layout of single-band class-E power amplifier designed individually.

III. SIMULATION RESULTS

The proposed dual-band class-E power amplifier was simulated using Agilent ADS at Cellular (836MHz) and 3G (1.95GHz) frequency. The transistor model used is MGF2415. At first, two different class-E power amplifiers are designed in Fig. 5.

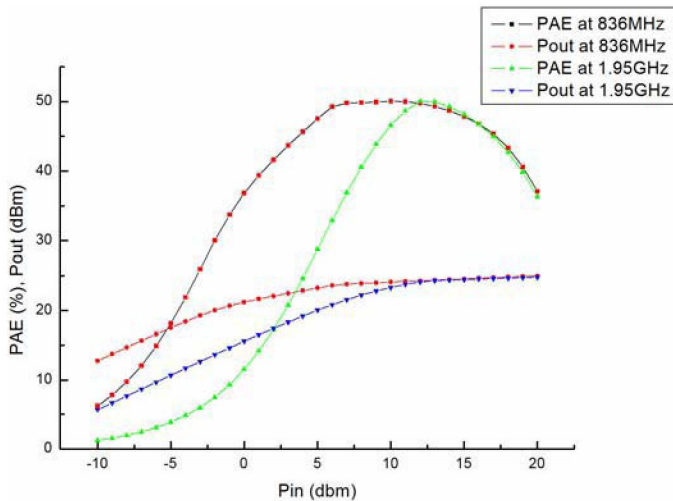

Fig. 6. The performances of single-band class-E power amplifier designed individually at 836MHz and 1.95, respectively.

Fig. 6 shows the output power and PAE of single-band class-E power amplifier designed individually at 836MHz and 1.95GHz. In this case, maximum output power of 24.9 dBm and 24.8 dBm, and PAE of 50.07% and 50.04% at 836MHz and 1.95GHz were obtained, respectively. Using this configuration, a dual-band class-E power amplifiers are designed.

Fig. 8 shows the output power and PAE of proposed dual-band class-E power amplifier at the two operating frequencies. In this case, maximum PAE of 48.63% and 48.29% were obtained at 836MHz and 1.95GHz, respectively. Maximum output powers were obtained almost the same values as those of each single-band class-E power amplifier.

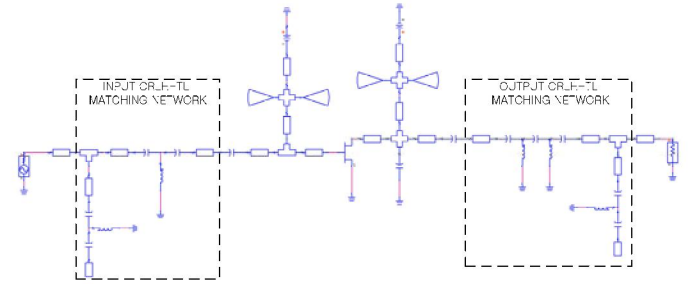

Fig. 7. The simulation layout of proposed class-E power amplifier at the two operating frequencies.

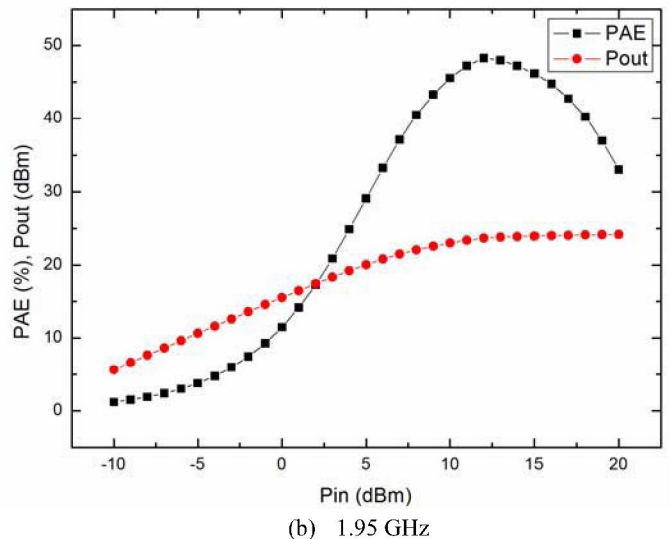
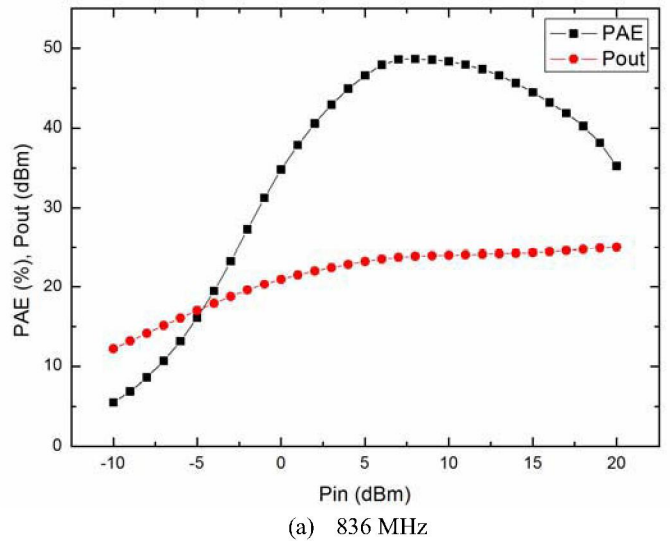

Fig. 7. The performances of proposed class-E power amplifier at the two operating frequencies.

Fig. 7 shows the output power and PAE of proposed dual-band class-E power amplifier vs. frequency. This result proves

a good performance of the proposed dual-band class-E power amplifier.

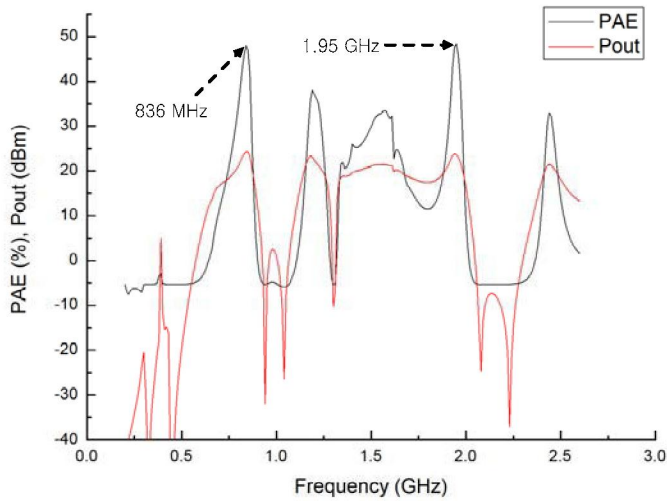

Fig. 7. The output power and PAE vs. frequency. (when $P_{in} = 12\text{dBm}$)

VI. Conclusion

The dual-band Class-E power amplifier using Composite Right/Left-Handed Transmission Lines are proposed. Dual-mode operation is achieved by the frequency offset and phase slope of CRLH TL for matching network. The frequency ratio of two operating frequencies is not necessarily an integer. We can control the phase response of CRLH TL as needed at two operating frequencies. Two operating frequencies are chosen 836MHz and 1.95GHz in this work. The simulated results

showed that output power of 24.9 and 24.1 dBm was obtained at 836MHz and 1.95GHz, respectively. In case of maximum PAE, we obtained 48.63% and 48.29% at two operating frequencies. The PAE of proposed dual-band class-E power amplifier reaches almost 96% performance of normal class-E power amplifier at individually two operating frequencies.

REFERENCES

- [1] Atsushi Fukuda, Hiroshi Okazaki, Tetsuo Hirota, Yasushi Yamao, Y. Qin, S. Gao, A. Sambell, and E. Korolkiewicz, "Novel 900 MHz/1.9 GHz Dual-Mode Power Amplifier Employing MEMS Switches for Optimum Matching," *IEEE Microwave and Wireless Components Letters*, vol. 14, no. 3, Mar. 2004.
- [2] V. Veselago, "The electrodynamics of substances with simultaneously negative values of ϵ and μ ," *Soviet Physics Uspekhi*, vol. 10, no. 04, pp. 509-514, Jan.-Feb. 1968.
- [3] C. Caloz, A. Sanada and T. Itoh, "A Novel Composite Right-/Left-Handed Coupled-Line Directional Coupler With Arbitrary Coupling Level and Broad Bandwidth," *IEEE Trans. Microwave Theory & Tech.*, vol. 52, no. 03, pp. 980-992, Mar. 2004.
- [4] I. Lin, M. Devincintis, C. Caloz, T. Itoh, "Arbitrary Dual-Band Components Using Composite Right/Left Handed Transmission Lines," *IEEE Trans. Microwave Theory & Tech.*, vol. 50, no. 04, pp. 1142-1149, Apr. 2004.
- [5] N. O. Sokal and A. D. Sokal, "Class E : A new class of high-efficiency tuned single-ended switching power amplifiers," *IEEE J Solid-State Circ SC-10* pp. 168-176, June 1975.
- [6] —, "Application of the transmission line theory of left-handed (LH) materials to the realization of a microstrip LH transmission line," *IEEE AP-S Int. Symp. Dig.*, vol. 2, 2002, pp. 412-415.